

TABLE OF CONTENTS

1. GENERAL.....	2
2. PRINCIPLE OF BROKEN TOOL DETECTOR.....	3
3. SAFETY PRECAUTIONS.....	4
4. MODEL SELECTION METHOD.....	6
5. SPECIFICATIONS.....	8
6. DIMENSIONS OF BROKEN TOOL DETECTOR.....	9
7. INSTALLATION.....	10
A. INSTALLATION INSTRUCTIONS.....	11
B. PROCEDURE FOR MOUNTING THE BROKEN TOOL DETECTOR.....	12
C. AIR EXHAUST LINE EXTENSION METHOD.....	13
D. COLLAR ALIGNMENT.....	15
E. NEEDLE ALIGNMENT.....	16
F. ORIGIN POSITION OF BROKEN TOOL DETECTOR.....	17
G. SENSING AREA OF NEEDLE IN 90 DEGREES.....	17
8. ELECTRIC WIRING DIAGRAM.....	19
9. PLC LADDER LOGIC DIAGRAM.....	20
10. COMMISSIONING OF THE BROKEN TOOL DETECTOR.....	21
11. ALARM CONDITIONS.....	22
12. TIMING DIAGRAM.....	23
A. TOOL NORMAL CONDITION TIMING DIAGRAM.....	23
B. TOOL BROKEN CONDITION TIMING DIAGRAM.....	24
13. ADVANTAGES, DISADVANTAGES & APPLICATIONS.....	25
A. ADVANTAGES.....	25
B. DISADVANTAGES.....	25
C. APPLICATIONS	25
14. MAINTENANCE AND TROUBLE SHOOTING.....	26

1. GENERAL

- Thank you for purchasing the DETECTOOL product broken tool detector. To obtain the best performance from your purchase be sure to read this manual carefully before use.
- The DETECTOOL broken tool detector models BTD – SD4 – R90 and BTD – SD4 – L90 are electro pneumatically operated broken tool detector.
- It has been designed for very accurate positive contact detection of broken tools like drills and taps. The device is compact and robust and can be operated at any desired angle.

2. PRINCIPLE OF BROKEN TOOL DETECTOR

- DETECTOOL broken tool detector detects the normal tool or broken tool just by conforming the rotating angle of a needle. It is actuated by pneumatic compressed air energy that causes rotary motion of a shaft in 90 degrees if a tool is broken and results in generation of an input signal to stop a machining operation.

3. SAFETY PRECAUTIONS

- To ensure proper use of the product be sure to read this manual carefully before starting installation, inspection, operation and maintenance.

This manual should be given to the person who actually uses the products and is responsible for their maintenance.

WARNING

Indicates a potentially hazardous situation which, if not avoided, will result in minor or moderate injury or may result in serious injury or death. Additionally, there may be significant property damage.

DANGER

Keep following item secure from danger:

1. Do not perform electrical wiring while power is ON.
2. Do not operate in combustible gas or explosive gas atmosphere.
3. Do not use in ambience of flammable products.
4. Do not decompose and modify.

The product may explode with following misuse:

1. Application of high air pressure beyond a given limit of 6.0 bar.

NOTICE

The product may damage with following misusages:

1. Application of unnecessary forces to tight the pneumatic fitting.
2. Application of unnecessary forces to tight the exhaust filter.
3. Application of unnecessary forces to tight the proximity sensor.
4. Forceful rotation of the needle holder / shaft to beyond 90 degrees.
5. Application of the compressed air without FRL unit.

SAFETY PRECAUTIONS

FIGURE NO. 1

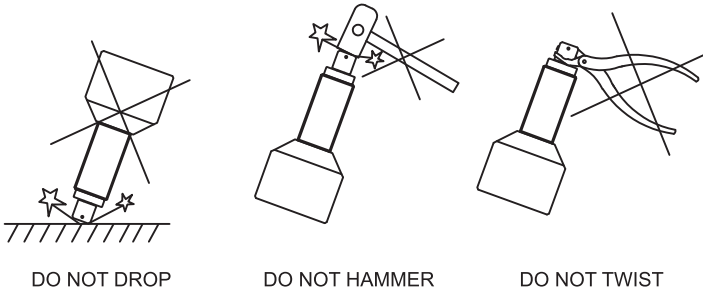

NOTE:

1. Do not insert / drop any part or other articles into the application port, the exhaust port and the sensor port.
2. Do not perform electrical wiring while power is ON.
3. Do not use the proximity sensor, the exhaust filter and the pneumatic fittings of other specifications.
4. Perform I / O wiring correctly.
5. Perform PLC program correctly as per given ladder logic.

4. MODEL SELECTION METHOD

- With the use of model no. 1: **BTD – SD4 – R90**, **figure no. 2** shows different rotating positions of the needle from the origin / start position to the end position while mounting on the LH and RH sides of the spindle, respectively.

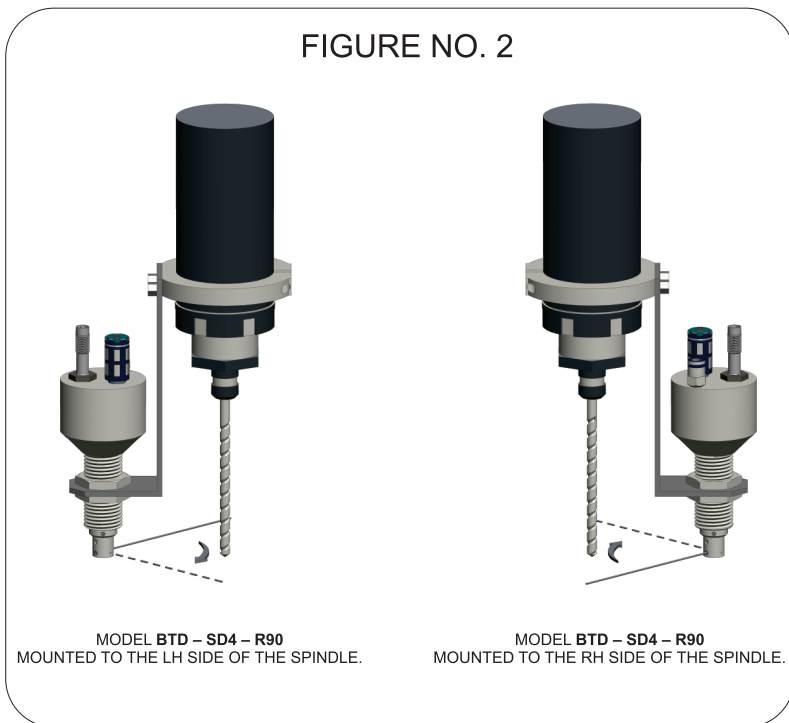

MODEL SELECTION METHOD

- With the use of model no. 2: **BTD – SD4 – L90**, **figure no. 3** shows different rotating positions of the needle from the origin / start position to the end position while mounting on the LH and RH sides of the spindle, respectively.

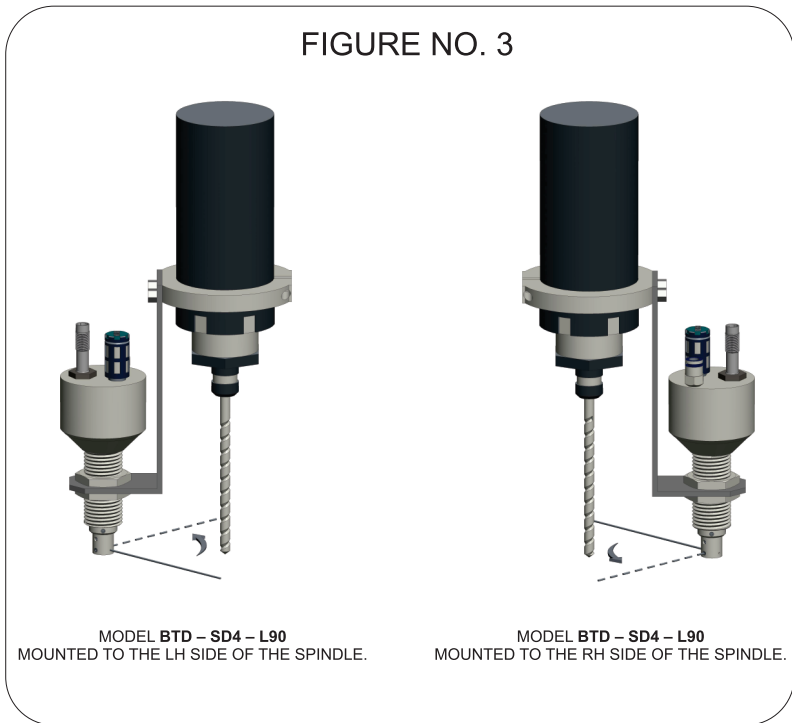

5. SPECIFICATIONS

1	Model	1) BTD – SD4 – R90 2) BTD – SD4 – L90
2	Proximity sensor	Size : M8, Sensing distance : 4mm, Torque : 7 N.M
3	Air pressure	4.0 – 6.0 bar
4	Exhaust filter	Size : 1 / 8
5	Pneumatic straight fitting	Size : M5 – 6
6	Needle length	Max. 100 mm round
7	Temperature (work area)	0°C ~ + 50°C (do not freeze)

7. INSTALLATION

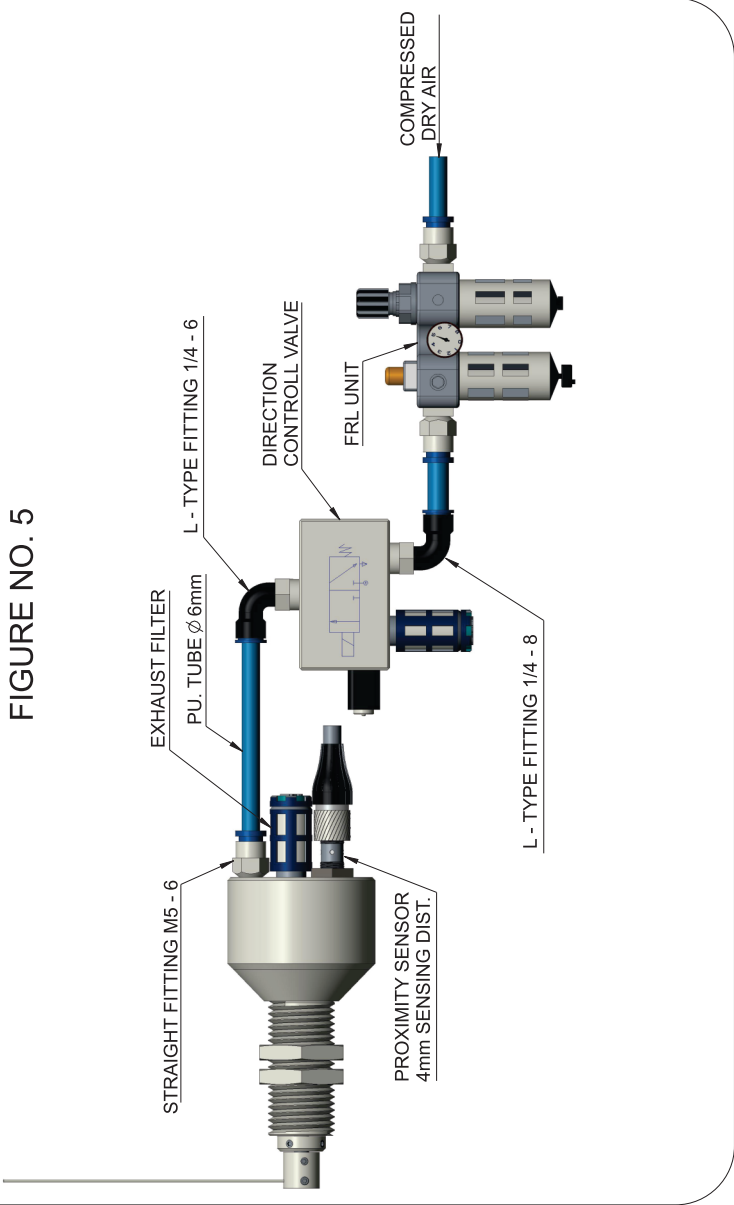

INSTALLATION

A. INSTALLATION INSTRUCTIONS

1. Tight / rotate the proximity sensor slowly into the sensor mounting port (S) until it comes to a stop then tight the lock nut.
2. Connect the connector type cable properly to the proximity sensor and then connect to the PLC.
3. Connect the pneumatic straight fitting of M5–6 properly to the port (A).
4. Connect the exhaust filter / silencer properly to the exhaust port (E).
5. Use M6 size pneumatic tube and do not use beyond 6 meter length from the direction control valve.
6. Use dry air to FRL unit and give through direction control valve to the port (A).

NOTE:

1. Do not apply unnecessary force as twisting, pulling, moment loads, etc on fitting, tubing, or on the proximity sensor.
2. Do not perform electrical wiring while power is ON.
3. Do the I / O wiring correctly as per the electric wiring diagram shown in **figure no. 12.**
4. Do the PLC programming correctly as per the PLC ladder logic diagram shown in **figure no. 13.**
5. Use only 4 mm sensing distance proximity sensor.
6. Using only 6 mm pneumatic tube is necessary.
7. Using dry air and FRL unit is necessary.
8. The bracket material for installation must have 3 mm or more thickness.
9. The needle should contact to the tool at least 2.0 mm from the tool tip.
10. Ensure that there is no restriction to the needle to rotate or move in 90 degree to check the drill or tap.

INSTALLATION

B. PROCEDURE FOR MOUNTING THE BROKEN TOOL DETECTOR

FIGURE NO. 6

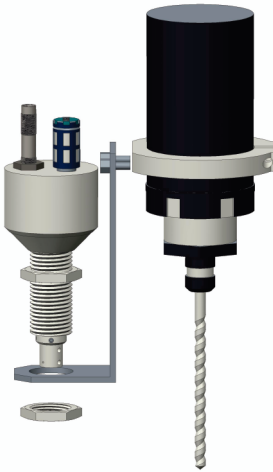
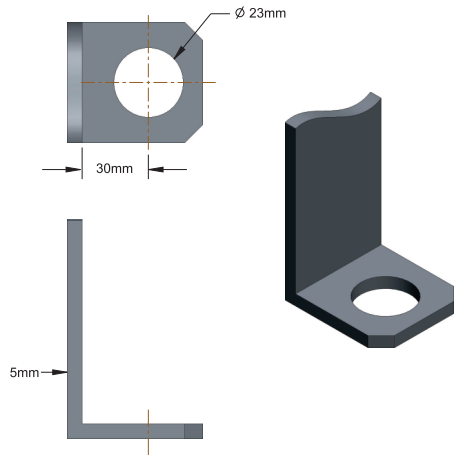

FIGURE NO. 7



1. Use L - type bracket of proper size and length as shown in **figure no. 7** to set/ align the needle easily on the tip of tool.
2. Mount the L-type bracket on the spindle properly as shown in **figure no. 6**.
3. Mount the broken tool detector on the L-type bracket and set the needle as the needle is capable of detecting / touching a tip of the tool in resting position as shown in **figure no. 10**.
4. After tightening the broken tool detector, make the grub screws of needle holder loose and set the required angle of needle holder with needle as shown in **figure no. 11** and tight the needle holder which is capable to adjust at any position within 360 degrees.

INSTALLATION

C. AIR EXHAUST LINE EXTENSION METHOD

After the installation of the broken tool detector, if the coolant pipes are close to the broken tool detector and if the coolant falls directly onto the Exhaust filter / silencer, there may occur coolant sprinkling due to air exhaust from the exhaust port (E) and choking up of the filter / silencer due to heavy burr falls thereon through the coolant. These conditions can be avoided by following the air exhaust line extension method as given below.

FIGURE NO.8

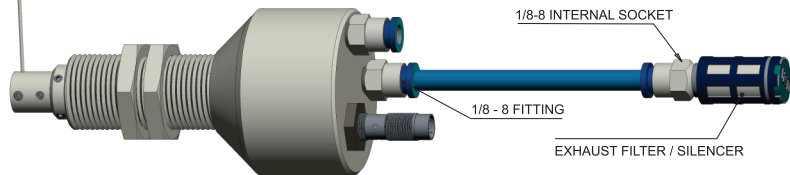

INSTALLATION

1. Remove the exhaust filter / silencer from the exhaust port (E) of the broken tool detector.
2. Tighten the pneumatic fitting of 1/8 – 8 mm size to the exhaust port (E).
3. Use the pneumatic pipe of maximum one meter length and M8 size.
4. Fit one end of the pneumatic pipe of M8 size into the pneumatic fitting fitted onto the exhaust port (E).
5. Fit the second end of the pneumatic pipe into another internal pneumatic fitting of 1/8 – 8 mm size as shown in the **figure no. 8**.
6. Fit the Exhaust filter / silencer into the internal pneumatic fitting as shown in the **figure no. 8**.
7. Once the above steps are completed, keep away the exhaust filter / silencer from the coolant.

NOTE:

1. Use only 1/8 – 8 mm of pneumatic fittings for the air exhaust line extension.
2. Do not use the pneumatic pipe of size below M8.
3. Do not use the pneumatic pipe of length beyond 1 meter.

INSTALLATION

D. COLLAR ALIGNMENT

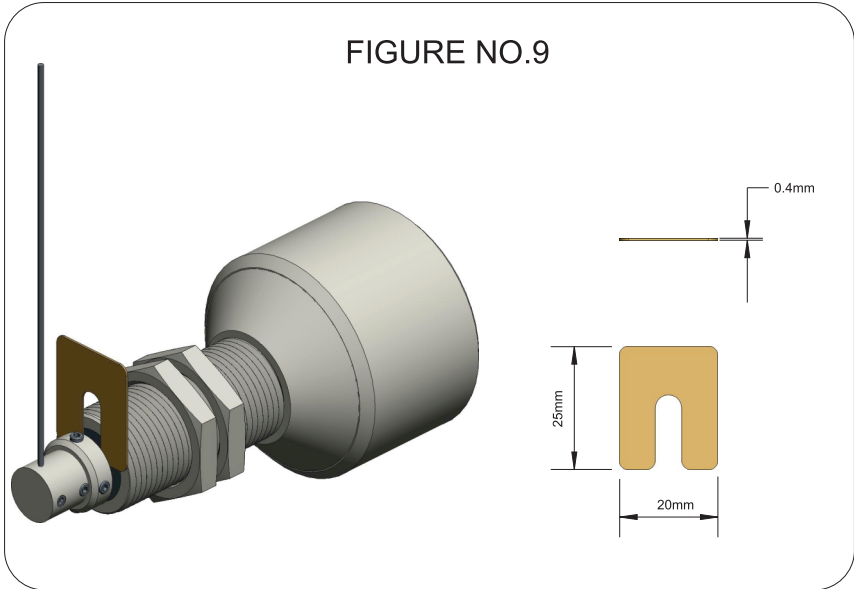

If the needle holder and collar are removed for cleaning bur then after cleaning bur collar alignment is necessary. The gap required between the collar and threaded piece is 0.4 mm. Any improper alignment of the collar will result in the needle getting struck or jammed while rotating in 90 degrees.

While doing needle alignment use the given 0.4 mm seam gauge. Insert the seam gauge between collar and threaded piece till the U shape rests on the shaft. Then smoothly rest the collar to the seam gauge and tight the grub screws of the collar and remove the seam gauge.

INSTALLATION

E. NEEDLE ALIGNMENT

FIGURE NO. 10

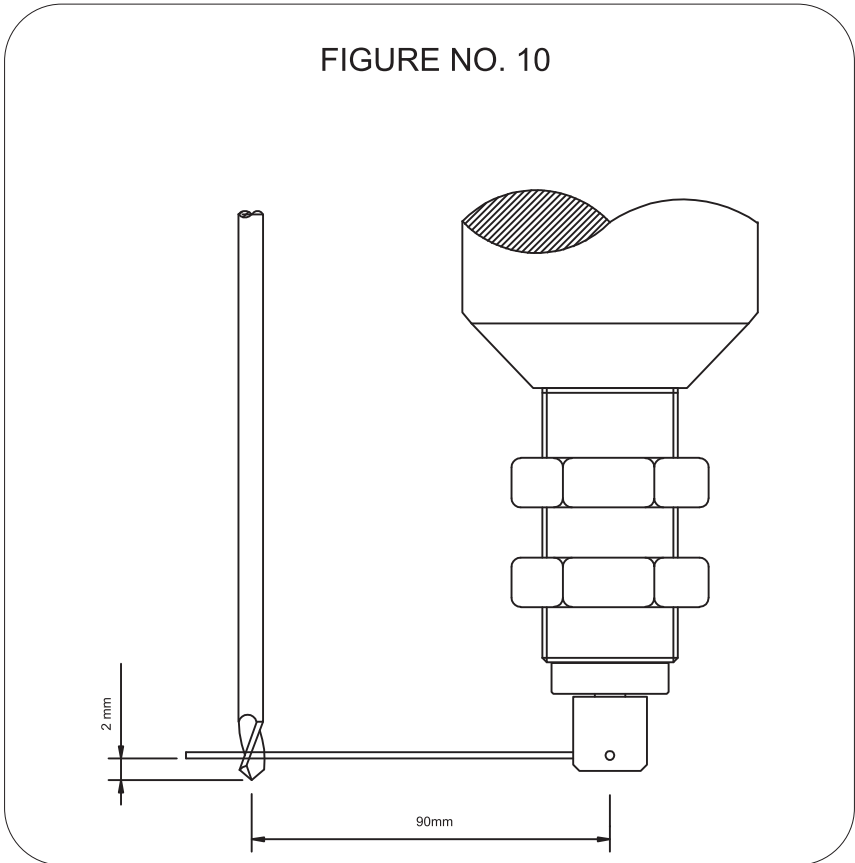

The standard length of the needle is 100 mm from the centre of axis. The touching part of the needle is at least 90 mm from the centre of axis and needle should be in contact with the tool at least 2.0 mm from the tool tip as shown in **figure no. 10**.

INSTALLATION

F. ORIGIN POSITION OF TOOL DETECTOR

When the shaft along with the needle rests in 0 degree, the proximity sensor generates the first input signal indicating that the tool detector device is in the default position and ready to be used for detection of tool breakage.

G. SENSING AREA OF NEEDLE IN 90 DEGREES.

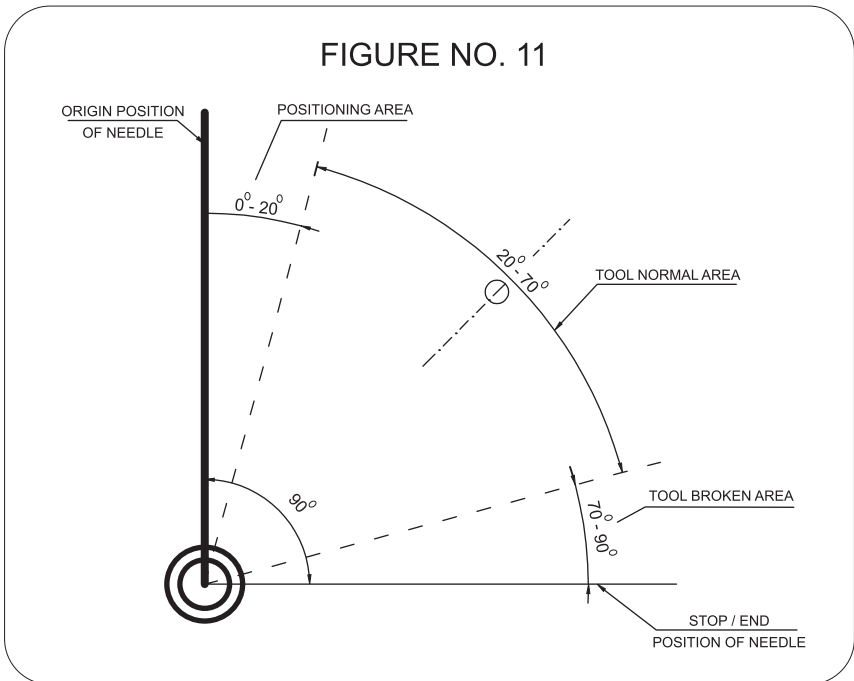

INSTALLATION

1. When the shaft along with the needle rotates between 0 – 20 degrees, the proximity sensor generates the first input signal. This is origin position of the tool detector.
2. The position of the shaft along with the needle after rotation to 0 – 20 degrees indicates movement thereof from the default position at which the proximity sensor turns OFF. If the shaft along with the needle rotates further and stops between 20 – 70 degrees, the proximity sensor remains OFF and the position indicates that the tool is in a normal condition.
3. If the shaft along with the needle continues to rotate further to complete rotation in 70 – 90 degrees, the position indicates that the tool is broken during which the proximity sensor turns ON to generate the second input signal.

8. ELECTRIC WIRING DIAGRAM

FIGURE NO. 12

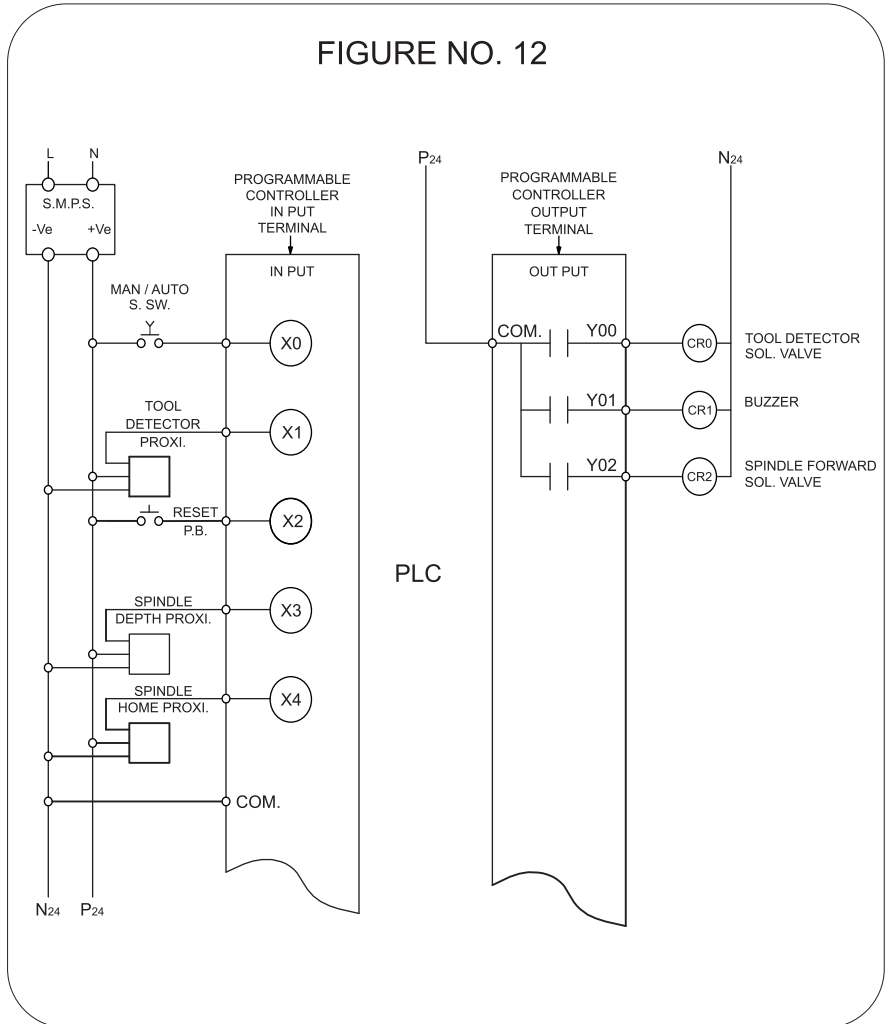

9. PLC LADDER LOGIC DIAGRAM

FIGURE NO. 13

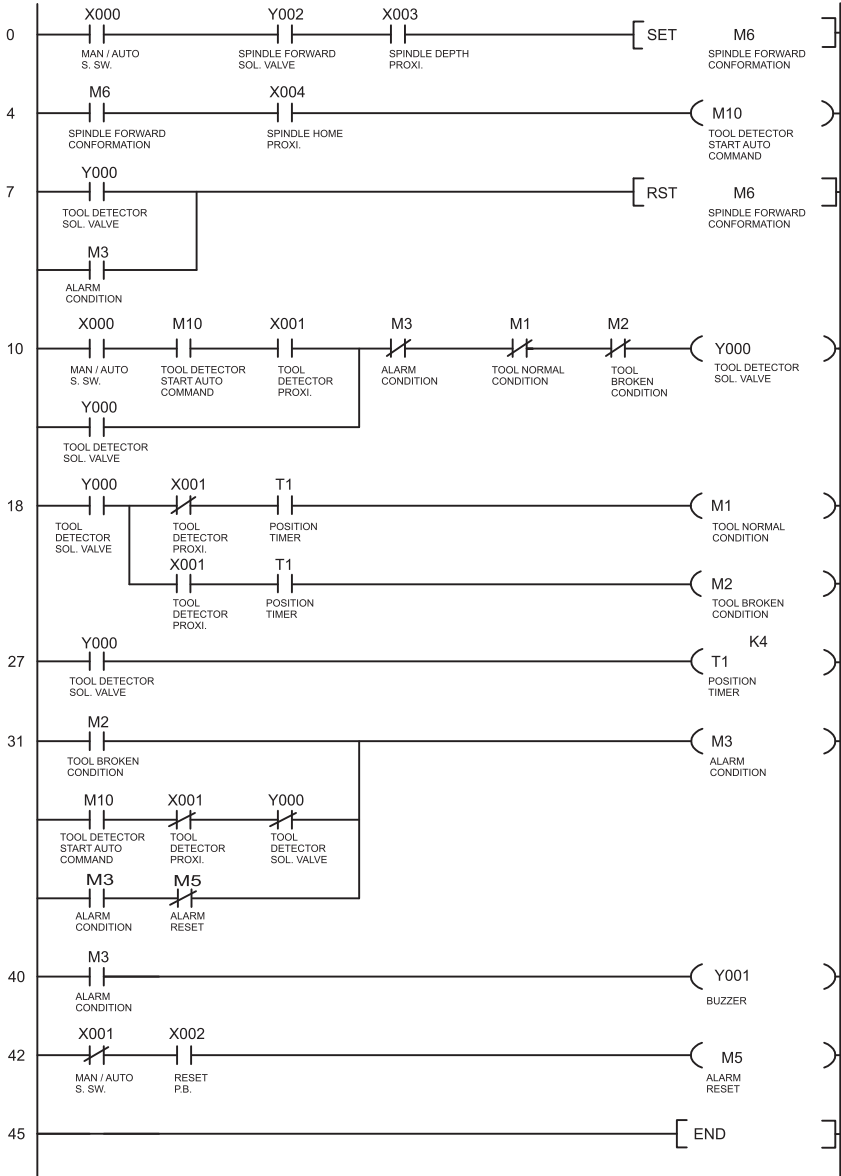

10. COMMISSIONING OF BROKEN TOOL DETECTOR

1. Make sure installation is properly done.
2. Make sure electrical hard wiring is properly done.
3. Make sure PLC programming is correctly done as per given ladder logic.
4. Make sure proximity sensor generating first input signal is in origin / start position.
5. Check the needle movement by hand. In 0 – 20 degrees, proximity sensor should remain on and generate first input signal. In 20 – 70 degrees, proximity sensor should turn off and in 70 – 90 degrees, proximity sensor should turn ON and generate second input signal.
6. Make sure the needle alignment is properly done with referring the needle alignment shown in **figure no. 10**.
7. Make sure the angle of needle is properly set as shown in **figure no. 11**.
8. Make sure air supply is given from FRL unit.
9. Make sure air supply is ON and pressure is between 4.0 – 6.0 bar.
10. For normal tool detection trial in auto mode after completion of drilling operation, the needle detects / touches a tip of normal tool that restricts complete rotation to 90 degree. The slight rotation of the shaft along with the needle between 20 – 70 degrees as a result proximity sensor does not generate the second input signal indicating that the tool is in the normal condition.
11. For broken tool trial slightly take needle back ward from the holder as the needle does not detect / touch the tool tip.
For broken tool trial in auto mode, the shaft along with the needle undergoes complete rotation to 90 degrees as the needle does not detect / touch the tool tip (the tool tip being broken fails to restrict rotation of the needle) and the proximity sensor generates the second input signal indicative of tool breakage resulting in discontinuation of the machining operation.

NOTE:

1. The needle will wear down because it touches cutting blade directly so it is necessary to check regularly.
2. The accurate detection will not be obtained if the lock nut or needle holder is loosened.
3. Regular inspection is necessary.
4. The exhaust filter / silencer should be replaced after every four months.

• **11. ALARM CONDITIONS**

The broken tool detector gives following alarm conditions with use of the PLC logic.

SR. NO	CONDITIONS	ALARM
1	Tool in normal condition	No alarm
2	Tool in broken condition	Alarm active
3	Proximity sensor short - circuit / continuous on	Alarm active
4	Proximity sensor open - circuit condition	Alarm active
5	Proximity sensor cable open - circuit condition	Alarm active
6	The shaft along with needle is struck in between 0 – 90 degrees	Alarm active

12. TIMING DIAGRAM

A. TOOL NORMAL CONDITION TIMING DIAGRAM

FIGURE NO.14

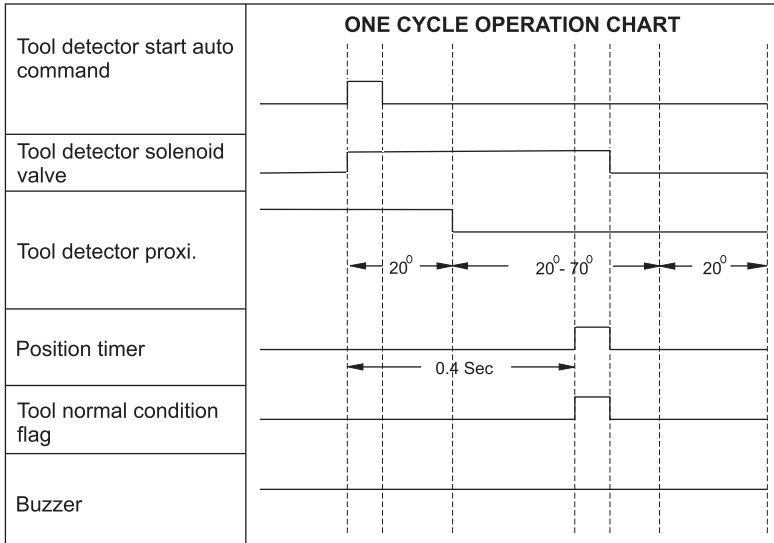

NOTE:

In tool normal condition, the needle should touch the normal tool tip in between 20 – 70 degrees before 0.4 sec. from the tool detector solenoid valve becomes ON. If the needle does not touch the normal tool tip in between 20 – 70 degrees before 0.4 sec, then consider that the needle is jam or bur enters into the gap between the collar and threaded piece or the collar alignment is disturbed.

TIMING DIAGRAM

B. TOOL BROKEN CONDITION TIMING DIAGRAM

FIGURE NO.15

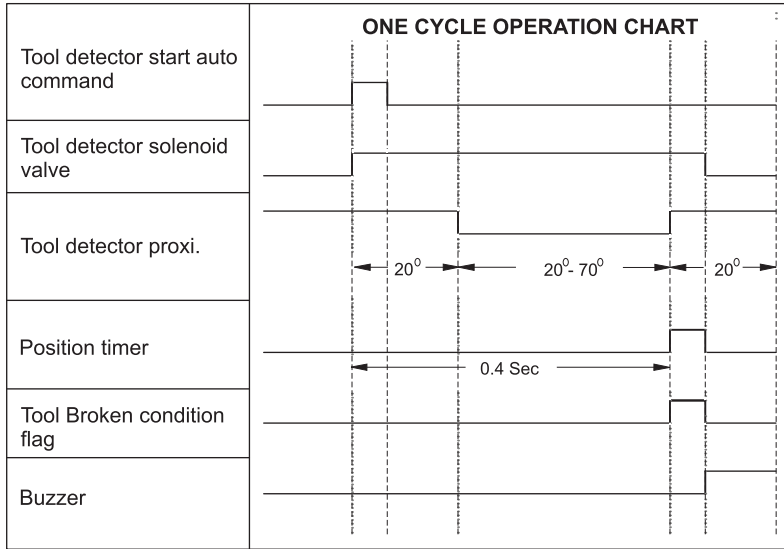

NOTE:

In tool broken condition, the needle should complete the rotation in 0 – 90 degrees before 0.4 sec. from the tool detector solenoid valve becomes ON. If the needle does not complete the rotation in 0 – 90 degrees before 0.4 sec, then consider that the needle is jam or bur enters into the gap between the collar and threaded piece or the collar alignment is disturbed.

13. ADVANTAGES, DISADVANTAGES & APPLICATIONS

A. ADVANTAGES

1. The broken tool detector is a robust electro-pneumatic device.
2. The broken tool detector suffers no frequent breakdown and hence has long life.
3. The proximity sensor, pneumatic fitting and exhaust filter are easily replaceable.

B. DISADVANTAGES

1. In case of low air pressure below 4.0 bar, chances of malfunctioning are possible.
2. In case the exhaust filter / silencer is choked up badly, the chances of malfunctioning are possible.

C. APPLICATIONS

1. CNC and SPM machines.
2. Drill machine tool break detection.
3. Part confirmation application.

14. MAINTENANCE AND TROUBLE SHOOTING

SR. NO.	PROBLEM	PROBABLE CAUSES	SOLUTION
1.	Shaft does not rotate properly by hand or does not return back to the original position or gets jam in 90 degrees.	<p>1. No gap between collar and threaded piece.</p> <p>2. Entry of heavy bur into the gap between collar and threaded piece.</p> <p>3. Air supply is not given from FRL unit.</p> <p>4. Needle stuck up to an object or coolant pipe.</p>	<p>1. Adjust 0.4 mm gap between collar and threaded piece with the help of seam gauge by referring figure no. 9.</p> <p>2. Remove needle holder and collar and clean bur by blowing air and tight the collar by adjusting 0.4 mm gap between the collar and the threaded piece with the help of seam gauge and set the angle of needle holder by referring figure no. 9 and figure no. 11 respectively and then tight the needle holder.</p> <p>3. Give the air supply from FRL unit.</p> <p>4. Separate out the object or coolant pipe and make the path clear to rotate the needle in 90 degrees.</p>
2.	Tool detector does not operate.	<p>1. Incorrect electrical hard wiring.</p> <p>2. Incorrect PLC programming.</p> <p>3. Air supply is OFF or air supply tube is kink or bent.</p>	<p>1. Check electrical hard wiring is correct.</p> <p>2. Check PLC programming is correct.</p> <p>3. Check air supply is ON and air supply tubes are not kink or bent.</p>

MAINTENANCE AND TROUBLE SHOOTING

3.	Alarm generation without any operation of the tool detector.	<ol style="list-style-type: none"> 1. Disconnected or loose proximity sensor cable. 2. Proximity sensor was not switched ON or not generating first input signal. 3. Proximity sensor cable is open / short circuited. 4. Air pipe has come out from fitting. 5. Cut or heavy air leakage in air pipe. 6. Low air pressure. 	<ol style="list-style-type: none"> 1. Check proximity sensor cable is properly connected. 2. Check proximity sensor and if faulty replace it. 3. Check proximity sensor cable if faulty replace it. 4. Connect air pipe properly to the fitting. 5. Replace the air pipe. 6. Increase air pressure upto 4.0 – 6.0 bar.
4.	Alarm generation without complete rotation of needle in 90 degrees.	<ol style="list-style-type: none"> 1. Needle stuck between 0 – 20 degrees to an object or coolant pipe. 	<ol style="list-style-type: none"> 1. Separate out the object or coolant pipe and clear the path for free rotation of the needle.
5	Tool detector does not detect the broken tool.	<ol style="list-style-type: none"> 1. Needle stuck between 20 – 70 degrees to an object or coolant pipe while operating. 	<ol style="list-style-type: none"> 1. Separate out the object or coolant pipe and clear the path for free rotation of the needle.

MAINTENANCE AND TROUBLE SHOOTING

5		<p>2. Entry of bur into the gap between collar and threaded piece.</p>	<p>2. Remove needle holder and collar and clean bur by blowing air and tight the collar by adjusting 0.4 mm gap between the collar and the threaded piece with the help of seam gauge and set the angle of needle holder by referring figure no. 9 and figure no. 11 respectively and then tight the needle holder.</p>
6.	<p>Generation of drill broken alarm when the drill is normal.</p>	<p>1. Improper alignment of needle w.r.t. the tool tip.</p> <p>2. Short length of needle.</p>	<p>1. Do the alignment of needle properly to the tool tip.</p> <p>2. Replace the needle.</p>
7.	<p>Proximity sensor does not become ON.</p>	<p>1. Improper fitment of proximity sensor or the proximity sensor has become loose.</p> <p>2. Proximity sensor is faulty.</p> <p>3. Proximity sensor cable is faulty.</p>	<p>1. Tight / rotate the proximity sensor slowly into the sensor mounting port (S) until it comes to a stop then tight the lock nut.</p> <p>2 Replace the proximity sensor.</p> <p>3. Replace the proximity sensor cable.</p>